

MAXI ECO FLOWATCH®

SICCOM

Maxi solenoid pump, compact and powerful, for the condensate removal of air conditioners up to 30kW / 100 000BTU.

Ref: DE40LCC300

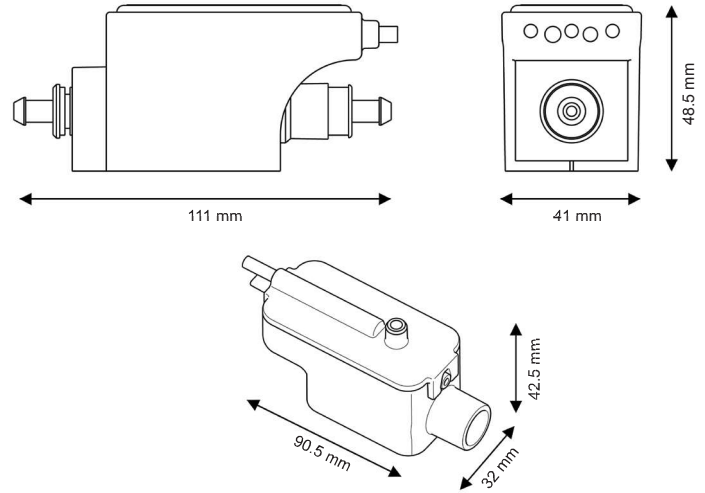
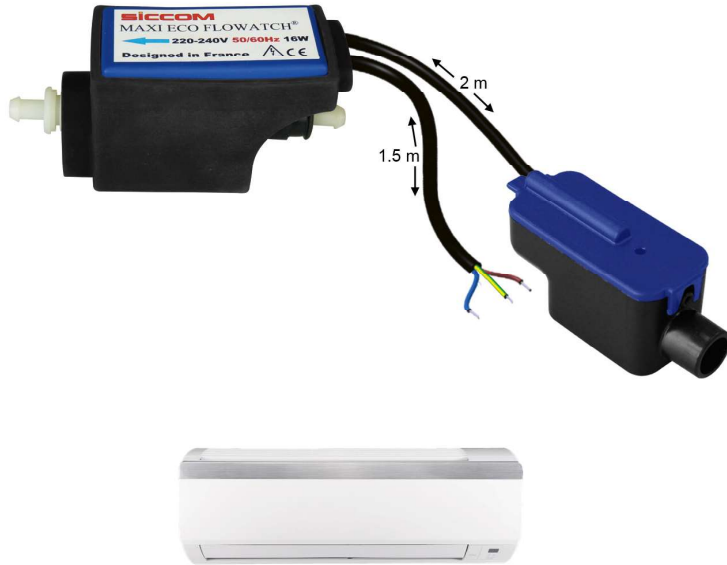

Hose diameter

Suction : 6/9 mm - not supplied
Discharge : 6/9 mm - not supplied

BENEFITS



Silent

The only pump of the world to offer such a flowrate with such a low noise.



High efficiency

Flowrate 40 l/h
Discharge head 10 m



Removable reservoir

Can be easily unclipped in order to clean the reservoir and the float.



Integrated filter

Plastic filter integrated to the reservoir. It prevents big impurities to damage the pump.



Accessories included

All necessary accessories are included in the box.



Compact pump

Very small, pump and reservoir are easy to install.



CONTENTS

Pump - Reservoir - Double-side adhesive for reservoir fixing - Inlet tube - 3 clamps

SPECIFICATIONS

Flowrate max	40 l/h
Suction head max	2 m
Discharge head	10 m
Electrical power	16W
Voltage	220-240V 50/60Hz
Alarm*	No alarm
Noise level**	
Protection rating	IP20
Thermal protection	Yes
Operating cycle***	100%
Power cable	1.5 m
Dimensions	111 x 41 x 48 mm / 90 x 32 x 42 mm

* Alarm option available on request.

** Notation from 1 wave (≤ 20 dBA) to 6 waves (> 45 dBA)

*** The pump is able to run 100% of the time if necessary.

FLOWRATE

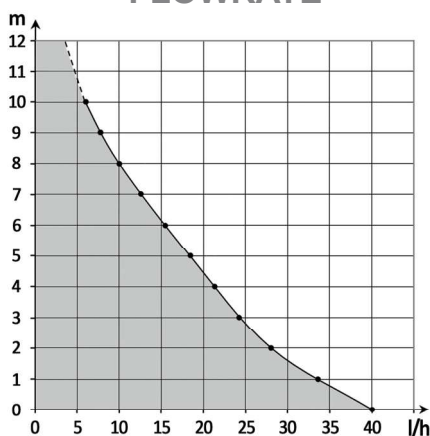

Authorized Distributor
APL ASIA CO., LTD.
11/129-132 Moo.5 Lam Lukka Rd., T.Kookut, A.Lam Lukka, Pathumthani 12130 Thailand.
TEL. 0-2995-4461-3, FAX. 0-2995-4464
www.apl-asia.com
EMAIL : sales@apl-asia.com
LINE@ : @APL-ASIA