

Combustible Gas Detector

E2610-LEL

User Manual



Table of contents

Acetylene	3
Butane	4
Hydrogen	5
Methane	6
Propane	7
Specifications	8
Product description	9
Safety requirements	9
Operating conditions	9
Installation guidelines	10
Connections	11
Operation	13
Maintenance	13
Calibration	13
Delivery set	14
Order code for E2610-LEL options	14
Warranty	15
Manufacturer contacts	15

Acetylene

A colorless flammable gas, lighter than air. Mixtures with air are explosive. It results from the interaction of calcium carbide with water. In industrial production, acetylene is mainly manufactured by the pyrolysis of light hydrocarbons.

Acetylene is widely used for welding and cutting of metals. The usage of acetylene as a feedstock in the chemical industry declines due to cost and environmental considerations.

Synonyms/Trade Names: Ethine, Ethyne.

Chemical formula	HC≡CH	
Molar weight	26	
Relative gas density (to air)	0.90	
Conversion	1 ppm = 1.06 mg/m ³	
Boiling point	-84 °C	
Low explosive limit (LEL), % vol. in air	2.3* (2.5**)	
Upper explosive limit (UEL), % vol. in air	100	
Odor	Odorless or with a faint ethereal smell if pure. The commercial-grade may have a garlic-like smell due to impurities.	
Hazards	Highly flammable. Gas/air mixtures are explosive. Forms explosive acetylide compounds with copper, mercury, silver & brasses (containing more than 66% copper). Asphyxiant. Non-toxic, but, when generated from calcium carbide, it can contain toxic impurities such as traces of phosphine and arsine.	
Exposure limits (NIOSH)	REL C	2662 mg/m ³ /2500 ppm

Butane

A colorless flammable gas that is heavier than air. The term "butane" is used for any of two structural isomers (n-butane or iso-butane, with unbranched and branched-chain respectively) or for their mixture. Occurs in light petroleum fractions.

Butane is used mainly as a fuel and as a feedstock in organic synthesis. It is applied also as a propellant in aerosol sprays and may be used as an ozone-friendly refrigerant.

Mixtures of butane with propane and other hydrocarbons are referred to as LPG (liquefied petroleum gas).

Chemical formula	n-butane $\text{CH}_3\text{CH}_2\text{CH}_2\text{CH}_3$	iso-butane $\text{CH}_3\text{CH}(\text{CH}_3)\text{CH}_3$
Molar weight	58	
Relative gas density (to air)	2.0	
Conversion	1 ppm = 2.38 mg/m ³	
Boiling point	-0.56 °C	-11.7 °C
Low explosive limit (LEL), % vol. in air	1.4* (1.6**)	1.5* (1.8**)
Upper explosive limit (UEL), % vol. in air	8.4	9.6
Odor	Gasoline-like odor	
Hazards	Highly flammable. Inhalation of butane can cause euphoria, drowsiness, narcosis, asphyxia, cardiac arrhythmia, fluctuations in blood pressure, and temporary memory loss, when abused directly from a highly pressurized container, and can result in death from asphyxiation and ventricular fibrillation.	
Exposure limits (NIOSH)	TWA 1900 mg/m ³ /800 ppm	Not established

Hydrogen

A colorless, odorless, flammable gas, that is much lighter than air. Mixtures with air are explosive. Results from the interaction of acids, bases, and water with active metals and from the electrolysis of aqueous solutions. In industrial production, the main source of hydrogen is hydrocarbons.

Chemical formula	H ₂
Molar weight	2
Relative gas density (to air)	0.07
Conversion	1 ppm = 0.0818 mg/m ³
Boiling point	-252.88 °C
Low explosive limit (LEL), % vol. in air	4.0
Upper explosive limit (UEL), % vol. in air	75
Odor	Odorless
Hazards	Flammable forms explosive mixtures with air. Asphyxiant.
Exposure limits	not established

Methane

A colorless flammable gas, the main component of natural gas, marsh gases. Methane results from bacterial decomposition of plant and animal matter (landfill gas).

Methane is widely used as a fuel and chemical feedstock.

Synonyms: Marsh Gas, Natural Gas, Carbon tetrahydride, Hydrogen carbide.

Chemical formula	CH ₄
Molar weight	16
Relative gas density (to air)	0.55
Conversion	1 ppm = 0.65 mg/m ³
Boiling point	-161.49 °C
Low explosive limit (LEL), % vol. in air	4.4* (5.0**)
Upper explosive limit (UEL), % vol. in air	15
Odor	Odorless when pure. Methane used in the kitchens contains an odorant
Hazards	Highly flammable, mixtures with air are explosive. Asphyxiant.
Exposure limits	not established

Propane

A colorless flammable gas that is heavier than air. It occurs in light petroleum fractions.

Propane is used mainly as a fuel and as a feedstock in organic synthesis. It is applied also as a propellant in aerosol sprays and may be used as an ozone-friendly refrigerant.

Mixtures of propane with butane and other hydrocarbons are referred to as LPG (liquefied petroleum gas).

Chemical formula	CH ₃ CH ₂ CH ₃	
Molar weight	44	
Relative gas density (to air)	1.55	
Conversion	1 ppm = 1.80 mg/m ³	
Boiling point	-42 °C	
Low explosive limit (LEL), % vol. in air	1.7* (2.1**)	
Upper explosive limit (UEL), % vol. in air	9.5	
Odor	Odorless when pure. Commercially available propane for fuel purposes may contain odorant ("gas smell").	
Hazards	Highly flammable, mixtures with air are explosive. Asphyxiant. May cause dizziness, confusion, excitation when inhaled.	
Exposure limits (NIOSH)	TWA	1800 mg/m ³ / 1000 ppm
	IDLH	2100 ppm [10%LEL]

Conversion of ppm to mg/m³ is calculated for 25°C and 1 atm.

* according to new EU standards ('stirred' concentration of gas)

** according to US standard ('still gas' method)

Specifications

Detected gas	Acetylene, Butane, Hydrogen, Methane, Propane
Sensor type	Metal Oxide Semiconductor
Sampling method	Diffusion
Detection range	0...100% LEL
Default alarm setpoints (release-LOW-HIGH)	7 - 10 - 25 %LEL
Response time	ca. 60 s
Sensor lifetime	>5 years
Calibration interval	12 months
Power supply	24 VDC/AC \pm 20% (default) or 230 VAC (optional)
Power consumption	< 2 VA
Digital interface	UART
Relay outputs	2 \times SPDT, max 5 A, 30 VDC / 250 VAC
Alarm signaling	Buzzer 2 kHz, 85 dB; red LED
LEDs	Green/red (operation/fault), red (gas alarm)
Enclosure	ABS plastic with ventilation slots, wall-mount, protection class IP20
Dimensions	H85 \times W85 \times D37 mm
CE marking	According to 2014/30/EU and 2014/35/EU, EN 50491-4-1:2012 EN 61000-6-3:2020, EN 61326-1:2013(EMC, emissions) EN 61000-6-1:2019, EN 61000-6-2:2019(EMC, Immunity) EN 60079-29-1:2016, EN 60079-29-2:2015 and EN 60079-29-3:2014
Operating conditions	-40...+70 °C, <95 %RH, atmospheric pressure \pm 10%; Explosion-safe (non-ATEX rated) spaces, Normal ambient oxygen level Avoid strong mechanical shock, vibrations or EMI Avoid exposure to corrosive gases or silicone-containing products.

Product description

E2610 series gas detectors are compact and easy-to-use instruments. The devices utilize novel fully calibrated and temperature compensated gas sensors with excellent repeatability, stability, and long lifetime.

Two relays with switch-over contact may be used for remote signaling or ventilation control. Flashing LED and an internal buzzer give alarms at two setpoints.

Safety requirements

Misuse will impair the protection of the product. Always adhere to the safety provisions applicable in the country of use.

Do not perform any maintenance operation with the power on. Do not let water or foreign objects inside the device.

Removal of the PCB from the enclosure voids the warranty. Do not touch the electronic components directly, as they are sensitive to static electricity.

Connection diagrams can be found in the connections section. The device might not perform correctly or be damaged if the wrong power supply is connected.

External circuits connected to the equipment should have sufficient insulation rating according to the environmental conditions and equipment power.

A disconnecting device that is marked as such and easily accessible should be included in the installation of this product.

Operating conditions

The device should be used both in a non-hazardous indoor area and in a basic electromagnetic environment, where the latter is defined in EN 61326-1. Avoid strong mechanical shock and vibrations. Avoid corrosive atmosphere and areas highly contaminated with dust, oil mist, etc. Keep the instrument away from direct sunlight. A sudden temperature or humidity change might affect the sensitivity of the sensor.

Installation guidelines

There are no precise rules or standards to follow when installing gas detectors. The following points must be taken into account:

- Application (the instrument is intended for leakage control.)
- Properties of the space under investigation (room geometry, direction, and velocity of airflows, etc.),
- For gases lighter than air install the sensor higher than the potential leakage/generation source or near the ceiling. Combustible gases lighter than air are hydrogen, methane, and acetylene. Propane and butane are heavier than air and tend to sink. It is recommended to place the sensor lower than potential leakage or generation source.
- The device should be accessible for maintenance and repair.

The aforementioned conditions above will affect the coverage area of the device. however, the coverage area for a detector is usually between 2.5 to 5 meters radius.

For early leakage detection install the sensor as close as possible to the potential leakage sources (flanges, valves, pressure reducers, pumps, etc.), taking into consideration other points listed above.

For general area monitoring without definite leakage sources, the detector should be distributed evenly in the room.

Do not locate the detector close to ventilation openings and strong air currents. Avoid the areas without air circulation (corners, niches) as well.

For personal safety control, the detectors are installed in the breathing zone (at the height of the head of people or animals). The recommended sensor position is vertical, pointing downwards.

Connections

1. Detach the base of the enclosure by gently pulling along four guiding pins.
2. Attach the base to the wall with two screws. (see drawings below).

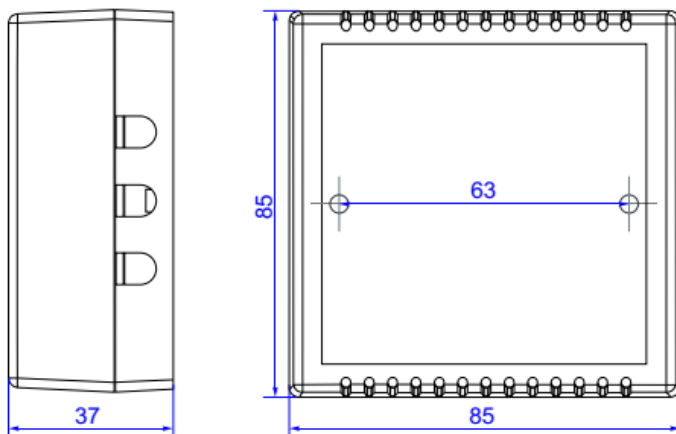

3. Use rounded cutouts on the side of the base to let in the cables from the power supply and of the external devices as shown below.

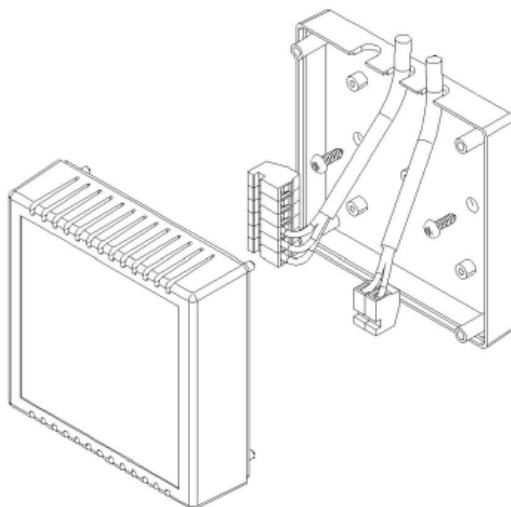

For easier connection, terminal blocks of E2610 series devices are removable. To dismount the terminal block, pull it off from the PCB. Connect the power terminals N and L to the 24 V power source if you are using detector version -24 or to 230 V AC mains if you are using detector version -230 (see diagram below).

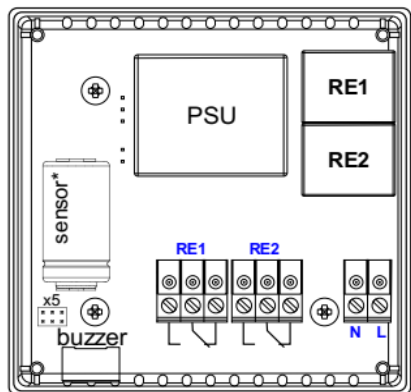

*Sensors may have different shape and/or size

Terminals	
RE1 NO	Relay 1, normally open terminal
RE1 COM	Relay 1, common terminal
RE1 NC	Relay 1, normally closed terminal
RE2 NO	Relay 2, normally open terminal
RE2 COM	Relay 2, common terminal
RE2 NC	Relay 2, normally closed terminal
L	90...265 VAC Phase (optional 24 VAC / VDC)
N	90...265 VAC Neutral (optional 24 VAC / VDC)

The terminals on the E2610 series devices are suitable for a wide range of wires with cross-section 0,2...1,5 mm². We recommend to strip the wire end by 5...6 mm and tin it, or to use the wire end sleeves. To connect the wire, loosen the screw, insert the wire end into the terminal hole and tighten the screw.

Connect external devices. Relay switch-over outputs may be used to control directly 24 V or 230 V (for versions -24 and -230 respectively) powered alarm sirens, ventilation fans, shut-off valves, or other actuators. Attach terminal blocks to the board.

4. Push enclosure to the base.

Operation

Turn on the power. During the first ca.60 seconds after powering on E2610 performs a warming-up and self-diagnostic routine, indicated by the flashing of each LED. The upper dual-color LED remains continuously green in normal operation and blinks red in case of device or sensor fault.

The warm-up time depends on the sensor type, unpowered period, and atmosphere. During the first 30 seconds after powering on you may select the automatic or manual mode of alarm release. By shortly (< 2 s) pressing the button on the device's front panel you enable the automatic mode, by pressing the button for 2...10 s – manual mode. The activation of the automatic mode is followed by a single LED blinking and acoustic signal. If manual mode is activated, the double acoustic and light signal follows.

If the gas concentration exceeds the LOW alarm setpoint, the bottom red LED starts flashing at a rate of 1 Hz, and the relay RE1 switches over. The first alarm stops automatically if the gas concentration drops below 70% of the LOW alarm setpoint.

If the gas level exceeds the HIGH alarm setpoint, the bottom red LED starts flashing and the buzzer starts beeping at a rate of 2 Hz, and also the relay RE2 switches over. Depending on the selected release mode, the HIGH alarm stops automatically or can be stopped by pressing the button, on condition that the gas level has dropped below 70% of the LOW alarm setpoint.

Beyond the warm-up period, holding down the button for 2...10 seconds and releasing causes E2610 to reset and perform the self-diagnostic routine for testing purposes. When holding the button down for over 10 seconds, E2610 imitates the reaching of the HIGH setpoint with the respective light and sound indication and switching over the relays.

Maintenance

Do not perform any maintenance operation with the power on.

Clean the device with a soft damp cloth. Do not use any abrasive cleaning agents. Do not immerse the device in water or any cleaning media.

Calibration

E2610-LEL detectors have been calibrated by the Manufacturer with standard gas mixtures before delivery. Provided that the sensor is used under moderate conditions, field recalibration is recommended every 12 months. Please contact your dealer for more information.

Delivery set

- Combustible Gas Detector E2610-CO
- Mounting accessories:
 - 2 screws and 2 plastic dowel plugs

Order code for E2610-LEL options

E2610 options	Order code
Integrated 90...265 V mains power supply module	E2610-LEL-230
Integrated 24 VAC power supply module	E2610-LEL-24VAC

Warranty

This product is warranted to be free from defects in material and workmanship for a period of one year from the date of the original sale. During this warranty period, the Manufacturer will, at its option, either repair or replace a product that proves to be defective. This warranty is void if the product has been operated in conditions outside ranges specified by the Manufacturer or damaged by customer error or negligence or if there has been an unauthorized modification.

Manufacturer contacts

Evikon MCI OÜ

Teaduspargi 7/9, Tartu

50411 Estonia

info@evikon.eu

www.evikon.eu

