

ECO LINE

SICCOM

Mini in-line pump (solenoid), ultra compact and easy to install, for the condensate removal of air conditioners up to 10kW / 36000BTU.

Ref: DE05SCC600

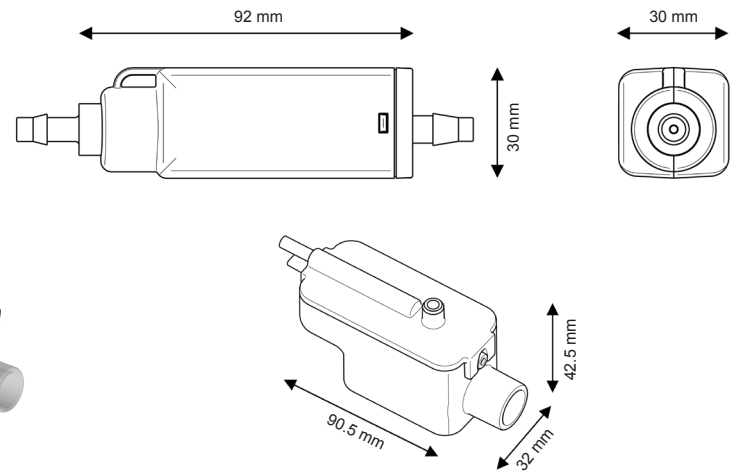
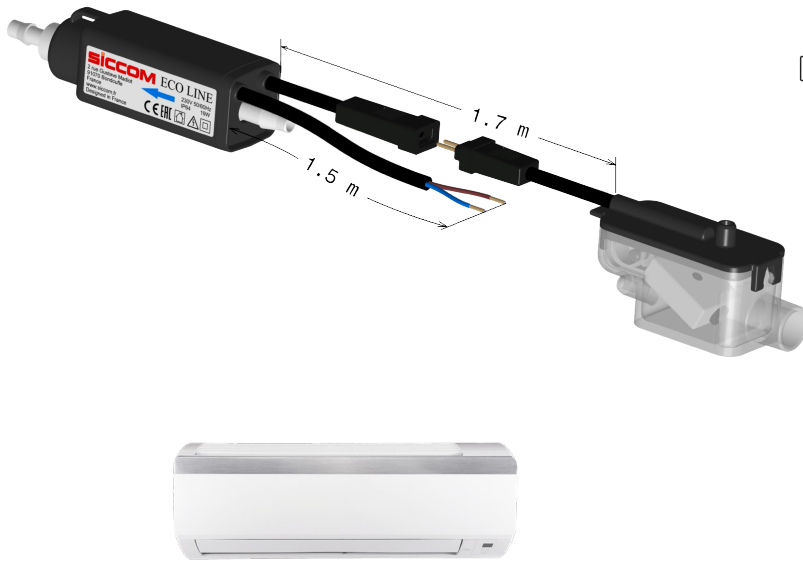

Hose diameter
Suction : 6/9 mm - not supplied
Discharge : 6/9 mm - not supplied

SPECIFICATIONS

Flowrate max	13.2 l/h
Suction head max	1.5 m
Discharge head	10 m
Electrical power	19W
Voltage	220-240V 50/60Hz
Alarm*	No alarm
Noise level**	
Protection rating	IP64
Thermal protection	Yes
Operating cycle***	100%
Power cable	1.5 m
Dimensions	92 x 30 x 30 mm / 90 x 32 x 42 mm

* Alarm option available on request.

** Notation from 1 wave (≤ 20 dBA) to 6 waves (> 45 dBA)

*** The pump is able to run 100% of the time if necessary.

BENEFITS

ULTRA COMPACT pump

The most compact pump of the market!
Easy installation in a duct or inside the air conditioner.



IP64 protection

Protected against water splashes and dust.

Quick connectors

Make installation and maintenance easier.

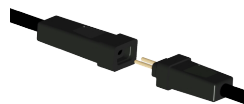

Removable clear reservoir

Allows a quick and easy viewing of the reservoir and the float. Easy to open and to clean.

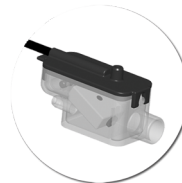

Hanging bracket

This astucious hook allows to fix or hang the pump wherever you want (duct, false ceiling, inside de unit...).



Accessories included

All necessary accessories are included in the box.



CONTENTS

Pump - Reservoir - Double-side adhesive for reservoir fixing - Inlet tube - 3 clamps

