

# mini FLOWATCH® 2

**SICCOM**

Mini solenoid pump reliable and silent for the condensate removal of air conditioners up to 10kW / 36000BTU.

Ref: DE05LC4400

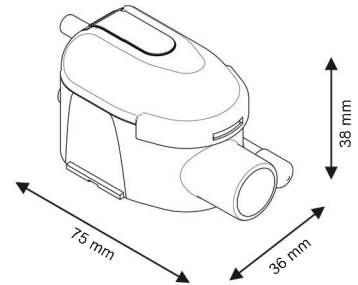
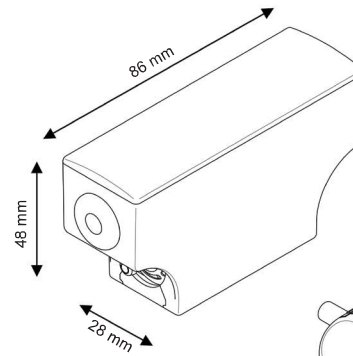

**Hose diameter**  
Suction : 4/6 mm - supplied  
Discharge : 6/9 mm - not supplied

## SPECIFICATIONS

Flowrate max	15 l/h
Suction head max	2 m
Discharge head	10 m
Electrical power	19W
Voltage	220-240V 50/60Hz
Alarm	NO-NC
Noise level*	
Protection rating	IP64
Thermal protection	Yes
Operating cycle**	100%
Power / alarm cable	1.6 m
Dimensions	86 x 28 x 48 mm / 75 x 38 x 36 mm

\* Notation from 1 wave (≤ 20 dBA) to 6 waves (> 45 dBA)  
\*\* The pump is able to run 100% of the time if necessary.

## FLOWRATE

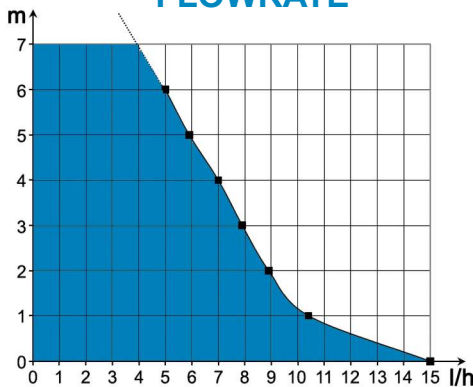

## Recommended accessory



### Kit Silence

Reduces the noise level and makes the installation easier.

Ref: GC1KFX2010

## BENEFITS



### Very silent

Very silent pump (20.2 dBA), suitable for an installation in any room.



### IP64 protection

Protected against water splashes and dust.



### Quick connectors

Make installation and maintenance easier.



### Clear reservoir

Facilitates maintenance thanks to a quick visualization of the reservoir state.



### Brass outlet

More solid and reliable than plastic outlet.



### Accessories included

All accessories required for installation are included in the box.

## CONTENTS



Pump - Reservoir with air-vent tube - Power / alarm cable - Reservoir stand - Double-side adhesive - Inlet tube - Suction tube 1.8m - 1 clamp



Authorized Distributor  
APL ASIA CO., LTD.  
11/129-132 Moo.5 Lam Lukka Rd., T.Kookut, A.Lam Lukka, Pathumthani 12130 Thailand.  
TEL. 0-2995-4461-3, FAX. 0-2995-4464  
www.apl-asia.com  
EMAIL : sales@apl-asia.com  
LINE@ : @APL-ASIA