



AIR CONDITIONING



REFRIGERATION



HEATING



# Mini Blanc<sup>®</sup>

## CONDENSATE REMOVAL PUMP

The 'ultra quick fit' Mini Blanc is designed to be fitted beneath high wall indoor units and offers easy access for future maintenance.



12L/h max. flow



10m max. rec. head (flow rate 4L/h)



21dB(A) @ 1m

### KEY FEATURES

- Extra quick to fit
- Compact & discreet
- Clear removable reservoir
- Ultra quiet operation

### SUITABILITY

- Up to 16kW / 54,000Btu/h
- High wall mini split systems
- ✓ **Perfect for...** Domestic use – where easy maintenance is key

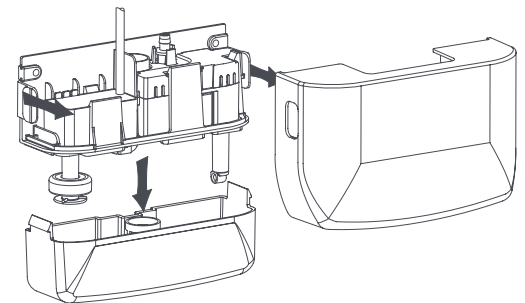
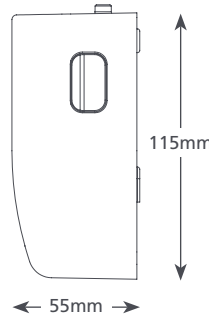
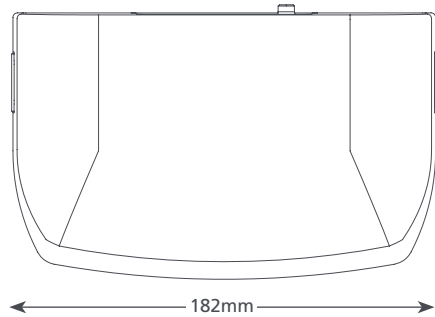

MINI BLANC @ 230 VAC 50Hz	
Max. flow	12L/h @ 0m head
Max. rec. head	10m
Tank capacity	0.24L
dB(A) @ 1m	21
Power supply	230 VAC, 0.11A, 19W 50/60Hz
Rated Class	Non continuous II appliance <input type="checkbox"/>
Max. unit output	16kW / 54,000Btu/h
Max. water temp	40°C / 104°F
Inlet/outlet	20mm in, 6mm out
IP Protection	IP21
Safety switch	3.0A Normally closed
Thermal protection	✓
Fully potted	Partially
Self priming	✓

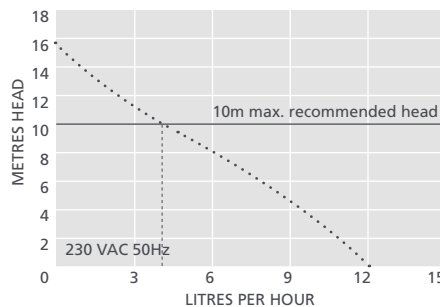

### SUGGESTED XTRA ACCESSORIES

Description	Part No.
1 Amp Fuse	FP2620
Tube To Soil Stack Adaptor	FP2038
Mini Blanc Ivory Cover	FP1037

**Xtra** For more installation accessories take a look at our Aspen Xtra range

### MINI BLANC OPTIONS

Mini Blanc (Europe)	FP1080/2
---------------------	----------

### IN THE BOX

Mini Blanc pump (including hard wired 1m power cable) • Anti siphon device • Drain connector kit • Fixing kit • Install manual

- Download manual at [aspenpumps.com](http://aspenpumps.com)
- View install video at [aspenpumps.com](http://aspenpumps.com)

Information correct at time of going to press.



[aspenpumps.com](http://aspenpumps.com)

+44 (0)1323 848842

[sales@aspenpumps.com](mailto:sales@aspenpumps.com)

reliable | silent | simple